

# FRIENDS OF THE COLUMBIA GORGE

## SPRING 1989 NEWSLETTER

### INSIDE THE NEWSLETTER

	Page
Will the Cows Come Back to Catherine Creek? .....	3
Gorge Commission News .....	4
FOCG Submits Recreation Inventory and Trails Proposal .....	4
Lawsuit Seeks to Invalidate National Scenic Area Act .....	4
Meet the Staff .....	5
1989 Annual Meeting Report .....	6
Special Membership Meeting: Members Support Board .....	6
Ninth Annual Gorge Hiking Weekend .....	7
FOCG Summer Picnic .....	7
Gorge Old-Timer's Corner: Mapping the Geology of the Gorge and Mount Hood in 1931 .....	8
Columbia River Gorge Guided Tour Tapes For Sale .....	10
In Remembrance: Glenn Replogle .....	10
Memorial Contributions .....	10
Maryhill Museum Features Gorge Landscapes .....	11
Volunteers Needed for Vegetation Screening Project .....	11

### GARBAGE TRUCKS ON GORGE HIGHWAYS?

On March 23, 1989, the Portland Metro Council voted to award a 20-year garbage hauling contract to a trucking company, Jack Gray Transport, Inc., of Gary, Indiana. Under this contract, the 2,635 tons of garbage generated daily in Portland, Oregon, will be trucked through the Columbia Gorge on Interstate 84 in overweight, over-sized trucks to the solid waste dump at Arlington. Round-trip, that means 188 pollution-producing trips per day along a scenic route travelled by most of the visitors to this newly-created National Scenic Area.

It was a surprise to learn in mid-February that trucks were one of the transport methods under consideration. Previous publicity had focused on rail or barge. Either of these methods would have far less impact on the Gorge. Only

*Continued on page 2*



*Vista House overlooking I-84 on a serene winter morning -- with no garbage trucks in sight.*

# GARBAGE TRUCKS ON GORGE HIGHWAYS? *Continued from page 1*

one barge-load or train trip a day would be needed, resulting in a fuel-savings of about 50%. Rail or barge transport would not create wear and tear on the highways. Only truck transport would endanger the lives of automobile travellers in the Gorge. In fact, statistics can be used to project the number of people who will be killed over the next 20 years as a result of the additional truck traffic -- about 15.

In making its decision, the Metro Council did not consult any of the agencies or organizations concerned with protection of the National Scenic Area. The trucking proposal was as big a surprise to the U.S. Forest Service and the Columbia River Gorge Commission as it was to Friends of the Columbia Gorge. Both agencies have opposed the trucking plan, saying that it is inconsistent with the purposes of the Columbia River Gorge National Scenic Area Act.

The price difference between the Jack Gray bid and the barge company's bid, the second-lowest bid, amounts to just 28 cents a month per household over the life of the contract -- but the cost

difference could narrow or disappear if the price of diesel fuel rises significantly over the next 20 years. Both the rail and barge options would use 50% less fuel and would be far less subject to cost increases in the event of a run-up in the price of petroleum.

It is ironic that Portland has taken this stand, since the City of Seattle, which recently began a similar bidding process for its garbage (twice the volume of Portland's), has specifically ruled out a truck contract, if the route would go through the National Scenic Area. Seattle took this position after both Friends of the Columbia Gorge and the Columbia River Gorge Commission contacted them to express concern at the impact on the Gorge. We have also written to King County, which is in the early stages of their bidding process.

Is the Portland decision final? According to Metro, it is. But Friends of the Columbia Gorge has learned that Jack Gray Transport must still obtain permits from the Public Utility Commission to operate its oversized trucks on the highway. These trucks will be almost 70 feet long -- longer than

most people's houses -- and fully-loaded will weigh 96,000 to 106,000 pounds -- 16,000 to 26,000 pounds overweight. Normally, the PUC hears only the case of trucking industry representatives in deciding whether to issue permits. But, in this case, we believe the public interest merits an independent review by the PUC staff, and we are urging the PUC to order this review.

In addition, we believe Metro's decision violates the counties' and communities' land use plans, and should be reversed by the Land Use Board of Appeals (LUBA). Accordingly, we plan to file an appeal with LUBA.

Other options we are studying include a voter referendum and state legislation to prevent the trucking of garbage through the Gorge.

We thank all of our members and others who have spoken out on this issue by writing to the Metro Council and attending hearings. The issue is far from resolved, and we will provide you with an update in the next issue of this newsletter.

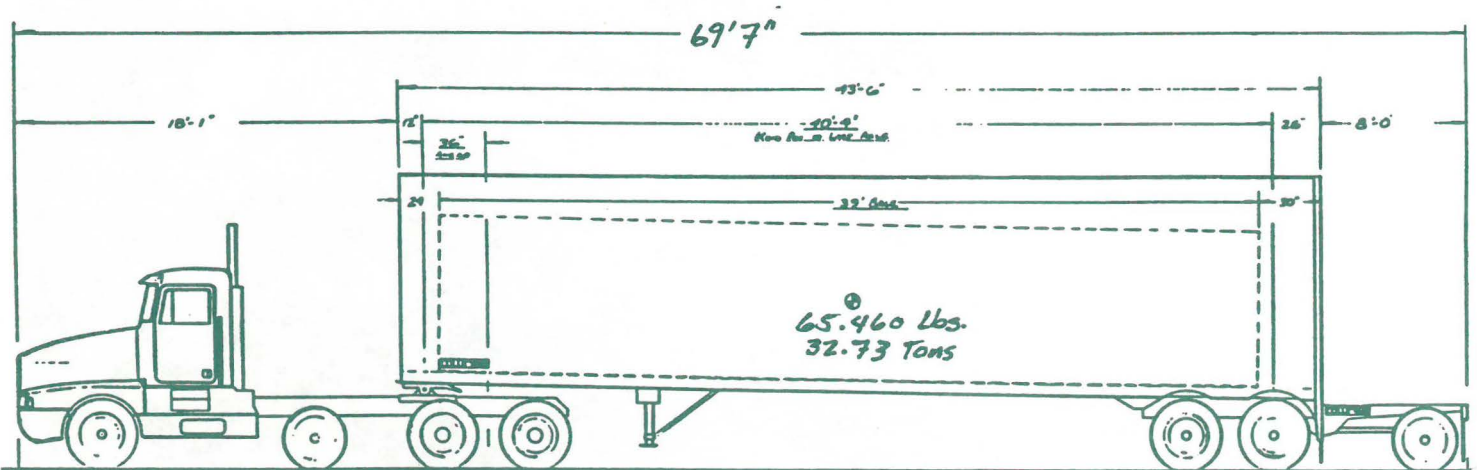

Diagram of oversized truck (almost 70 feet long) planned for use in hauling garbage to the Arlington dumpsite. Full trucks will weigh between 96,000 and 106,000 pounds. Empty trucks on the return trip will be difficult to maneuver in Gorge winds.



*Catherine Creek is a wildflower paradise since the cattle were removed from the area.*

## WILL THE COWS COME BACK TO CATHERINE CREEK?

Catherine Creek is an extraordinary wildflower area between Lyle and Bingen, Washington. In 1985, the 1,900-acre Lauterbach ranch property at Catherine Creek was acquired by the Trust for Public Land -- primarily in order to protect its botanical treasures. Seven wildflower species which grow here are listed by the Washington Natural Heritage Program as "threatened" or "sensitive," with another four species on the "monitor" list. In 1987, when funds became available from Congress under the Columbia River Gorge National Scenic Area Act, the ranch was acquired by the U.S. Forest Service and is now publicly owned.

For the last four years, people have been able to visit Catherine Creek in the spring without encountering cows, cowpies, trampled and cropped grass and wildflowers, muddy areas full of hoof-prints, and devegetated streambanks. We have never seen it looking so good. Plants which cattle love to eat, such as Balsam-root, Mariposa lilies, and native bunch-grasses, have started their comeback.

Recently, however, it was suggested that one way of reducing a supposed "fire hazard" at Catherine Creek would be to return cattle to the area. This would be a terrible idea.

If there is indeed a fire hazard at Catherine Creek, it can be readily controlled through the use of prescribed burning. The Forest Service is expert at prescribed burning of grasslands. Unlike grazing, prescribed burning is actually beneficial to the native plant communities, all of which evolved under conditions of periodic fires. Prescribed burning could be applied selectively to those parts of the Catherine Creek area where it was judged to be needed. In fact, prescribed burning is included in the management plan for The Nature Conservancy's Tom McCall Preserve on the Oregon side of the Gorge.

A recent report to the Gorge Commission by the Washington Natural Heritage Program recommends that the Forest Service develop a management plan for the area that is "directed toward maintaining the site's natural diversity,

improving the condition of the plant communities and maintaining viable populations of rare plant and animal species." Grazing was judged "not compatible" with the recommended goals, since it would promote continued invasion of the area by alien plants which would eventually "degrade the site to a poor and unrecoverable condition."

To put things in perspective, almost all of the grassland in the east Gorge is currently available for grazing. The only substantial exceptions are the Catherine Creek area and the Tom McCall Preserve and Mayer State Park complex on the Oregon side.

If you want to see cattle stay out of Catherine Creek, so that this remarkable wildflower area can continue to recover and thrive, please write to the Forest Service and to the Gorge Commission. Address your letters to:

James R. Bull, District Ranger  
Mt. Adams Ranger District  
U.S. Forest Service  
Trout Lake, Washington 98650

## GORGE COMMISSION PLANS LAND USE DESIGNATIONS

Land use designations for both the Special Management Areas and the General Management Areas of the National Scenic Area are due by July of 1989. In 1990, the permanent management plan for the Gorge is due. The Gorge Commission and Forest Service are now in the analysis phase of their work toward the both the land use designations and the permanent management plan.

Eight different "tracks" are being studied during this phase: scenic resources, natural resources, cultural resources, agricultural lands, forest lands, residential and commercial areas, recreation, and economic development. Friends of the Columbia Gorge will be keeping a close watch on this process to assure that the Act's mandate to protect and enhance the Gorge's important resources is upheld.

## FOCG SUBMITS RECREATION INVENTORY AND TRAILS PROPOSAL

Friends of the Columbia Gorge has submitted to the Gorge Commission and Forest Service a proposal for 40 new hiking trails in the Gorge. The proposed trails are in many areas of the Gorge, but special emphasis has been given to the Washington side of the Gorge. Although the Oregon side has over 200 miles of hiking trails, very few trails now exist on the Washington side.

A recreation inventory, describing future recreation opportunities in the Gorge, has also been submitted. The inventory includes 16 scenic drives, 16 proposals for new parks, additions, or campgrounds, and a variety of suggestions for roadside parks, picnic areas, and scenic turnouts.

We were fortunate to have the skilled assistance of Tom McGuire, a planning intern from Portland State University. Tom put many hours into ground-checking, mapping, and writing the final reports. Chairman Emeritus Nancy Russell and volunteer Russ Jolley also assisted. We hope the proposals will be included in the permanent management plan for the Gorge.

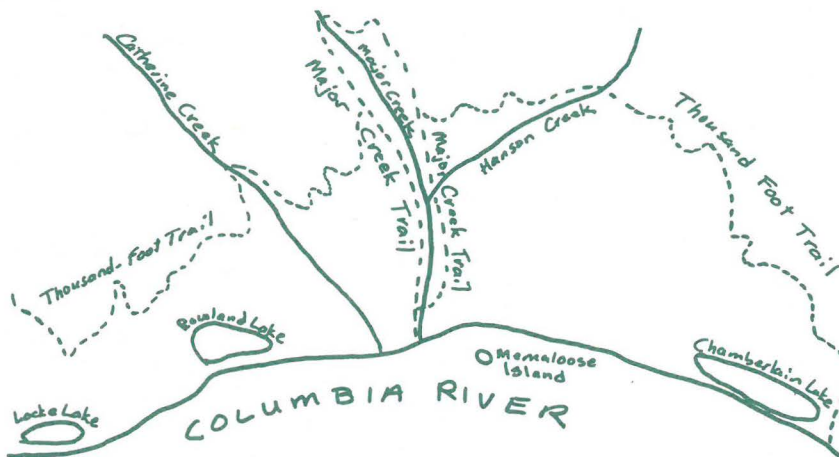

Map shows two trails proposed for the Washington side of the Gorge: Thousand-Foot Trail, proposed for the Catherine Creek area and Rocky Flat, and Major Creek Trail, which goes through a section of virgin forest recently saved from the chainsaws.

## NO SLOWDOWN IN DEVELOPMENT APPLICATIONS

Development pressures in the Gorge remain heavy. Last year the Gorge Commission considered 190 development proposals. January and February were their slow months with 8 and 9 proposals, respectively. Proposals peaked in August, with 24.

This year, development proposals are up over 75%, with 62 development proposals submitted from January 1 through March 27. This heavy volume of development proposals shows how important it will be for Friends of the Columbia Gorge to continue monitoring the development review process. We must counter the pressures for development with a balancing pressure for preservation of the Gorge, so that the new Columbia River Gorge National Scenic Area Act remains a strong force for protection of the Gorge.

## LAWSUIT SEEKS TO INVALIDATE NATIONAL SCENIC AREA ACT

Last November, a lawsuit was filed in federal court by Columbia Gorge United, seeking to invalidate the Columbia River Gorge National Scenic Area Act, or to weaken its effect in a number of ways.

Friends of the Columbia Gorge has formally intervened as a party to this suit, in order to protect our members' interest in comprehensive protection for the Gorge. The Sierra Club Legal Defense Fund (SCLDF) has agreed to represent us on a "pro bono" basis. This means that we will not be charged legal fees, only out-of-pocket costs such as filing fees, travel, etc.

SCLDF, which opened an office in Seattle recently, represented the Friends last year in our efforts to protect an area of old growth forest along the White Salmon River. Today, that forest is still standing, and has been included within the protection boundaries for the White Salmon Scenic River.

With the assistance of our SCLDF lawyers, we feel confident of success in upholding the Act.

## MEET THE STAFF



### EXECUTIVE DIRECTOR MARGARET DONSBACH

In January, Friends of the Columbia Gorge hired Margaret Donsbach as Executive Director. The job description for that position has been revised, and the Executive Director now has primary responsibility for administration, public education activities and fundraising. The National Scenic Area Act Implementation Program and other Gorge protection activities will be the responsibility of the Friends' Land Use Counsel. This new division of responsibilities will enable the Executive Director to concentrate on management functions, freeing the General Counsel to proceed "full steam ahead" in protecting the Gorge.

Ms. Donsbach began her career in nonprofit development as assistant to the director of The Nature Conservancy's California Field Office. She then served as director of development for the Museum of Modern Mythology, a small museum in San Francisco, where she obtained the Museum's first foundation grant and developed membership programs for both individuals and businesses.

### LAND USE COUNSEL GARY KAHN

After a lengthy search for the right person to spearhead the Friends' Gorge protection program, we have entered a two-year contract for the services of a highly experienced natural resources lawyer. Gary Kahn is an attorney with the Portland firm Reeves & Kahn. While retaining his position at Reeves & Kahn, he will take on Friends of the Columbia Gorge as his primary client, handling the bulk of our work to protect Gorge resources.

Mr. Kahn received his B.A. in zoology from Ohio State University, graduating with honors in 1977. In 1981, he received a law degree from the University of Oregon, also with honors, with a specialty in environmental law. From 1981 through 1987, he worked for the U.S. Department of Agriculture, first in Washington D.C. and then in Portland, Oregon. Most of his work during that time was for the Forest Service, and included work on the Columbia River Gorge National Scenic Area Act. Since 1987, he has been in private practice.

Mr. Kahn's experience will be put to good use. His top priority project will be to work with both the Forest Service Columbia Gorge office and with the Gorge Commission as they develop the land use designations and the permanent management plan called for under the National Scenic Area Act. He will also be the Friends' representative on the Klickitat/White Salmon Rivers Task Force, will monitor development applications for Gorge lands, and generally perform all of the necessary work of the Friends in monitoring threats and preventing damage to important Gorge resources.

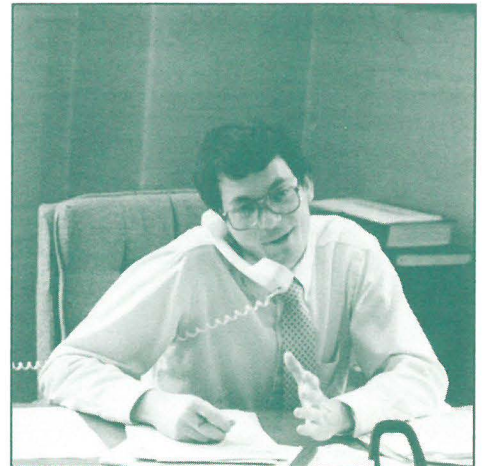

### OFFICE MANAGER CHERYL DYE

Cheryl Dye was hired in December, 1988, to serve as Office Manager for Friends of the Columbia Gorge. She is a graduate of Western Business College, where she concentrated on computer skills and bookkeeping.

As we go to print, Ms. Dye is in the final stage of setting up the organization's new double-entry bookkeeping system -- a sophisticated system which involves a separate income journal, expense journal, general journal, and general ledger.

Ms. Dye also supervises our crew of office volunteers who answer telephones and assist with clerical tasks, and she manages our computerized membership records. If you have a question about your membership status, call her -- she will be happy to help you.

# 1989 ANNUAL MEMBERSHIP MEETING



*Philip Jones accepts his volunteer award from Chairman Bowen Blair, Jr.*

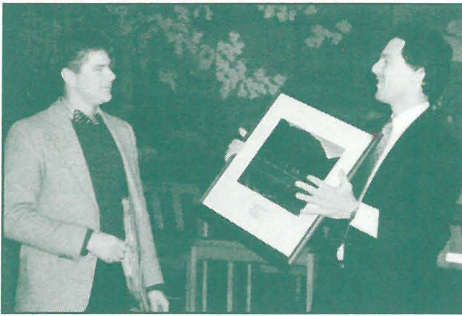

*Hal Howard ready to accept his award.*



*Nancy Russell expresses her appreciation.*

The 1989 Annual Membership Meeting of Friends of the Columbia Gorge was held the evening of March 30, 1989, at the Portland Garden Club in Portland, Oregon. About 50 members attended and heard reports by Chairman Bowen Blair, Jr., Treasurer B.H. Bishop, and Executive Director Margaret Donsbach.

One board member was due for ratification this year, Henry Wessinger, who was elected to the board on January 11, 1989, for a term of two years. Mr. Wessinger works for Shearson Lehman Hutton, and has been a very active participant since he joined the board. The members voted to ratify his election.

Three Volunteer Awards were presented. All received framed color photographs of Gorge scenes by noted photographer Ron Cronin. The volunteers honored were:

Philip Jones, a lawyer and long-time member who worked energetically and successfully to avert the siting of the Port of Entry at the portal of the Gorge near Lewis and Clark State Park, and more recently to help protect Friends of the Columbia Gorge from the lawsuits filed against it.

Hal Howard, a lawyer who has put in many hours assisting FOCG in work to protect the White Salmon River, monitoring Gorge Commission decisions, and providing legal expertise during the interim period before our new Land Use

Counsel was hired.

And Nancy Russell, a founder of the Friends who has worked tirelessly ever since to protect the Gorge and to shepherd the organization through many times of struggle and challenge. Mrs. Russell served as Chairman until she stepped down from that position last June.

A brief but lively discussion period allowed members to ask questions about some of the issues brought up in the reports. Members were particularly interested in what they could do to prevent the plan to turn I-84 into Portland's garbage route to Arlington (see article on page 1). The meeting was adjourned at about 6:45 p.m., and guest speaker Terence O'Donnell spoke on "The Face of a Place, The Impact of Nature and Man on the Landscape of Oregon."



*Terence O'Donnell.*

## SPECIAL MEMBERSHIP MEETING: MEMBERS VOTE TO SUPPORT BOARD

Many members of Friends of the Columbia Gorge were surprised to receive notice of a Special Membership Meeting on March 19, 1989, mailed to them by a group calling themselves "Friends of the Friends." The notice just met the minimum 7-day requirement set forth in our bylaws.

In February, this group had sent a mailing to our membership, which included a postcard calling for a special meeting. Members of the group include former executive director Brad Jones (who was dismissed in December) and former board member Linda Hopkins. Both have filed lawsuits against Friends of the Columbia Gorge.

Despite the short notice, close to 400

people attended the meeting, held at the Westminster Presbyterian Church in Portland. Most were members, although non-members were not excluded from the meeting.

Chairman Bowen Blair, Jr. presided over the meeting, which followed the written agenda prepared by the "Friends of the Friends" group. Presentations were made by Brad Jones and by the Board of Directors. The floor was then opened to questions and discussion by the membership, followed by a period of motions and votes.

The membership voted to express its complete support and confidence in the Board of Directors of Friends of the Columbia Gorge. They also voted to

recommend permanent removal of Brad Jones as a member, following the procedures set forth in the bylaws. (Mr. Jones' membership expired on April 1, 1989. At its next meeting, the board will consider the appropriate response to this membership vote.) Finally, the members voted to call upon Mr. Jones to drop his lawsuits against Friends of the Columbia Gorge and its board members, as a sign of good faith. (As we go to press, the lawsuits have not been dropped, and are still pending.)

Minutes of the meeting are on file at the Friends of the Columbia Gorge office, and will be provided to members who request them.

# NINTH ANNUAL GORGE HIKING WEEKEND SET

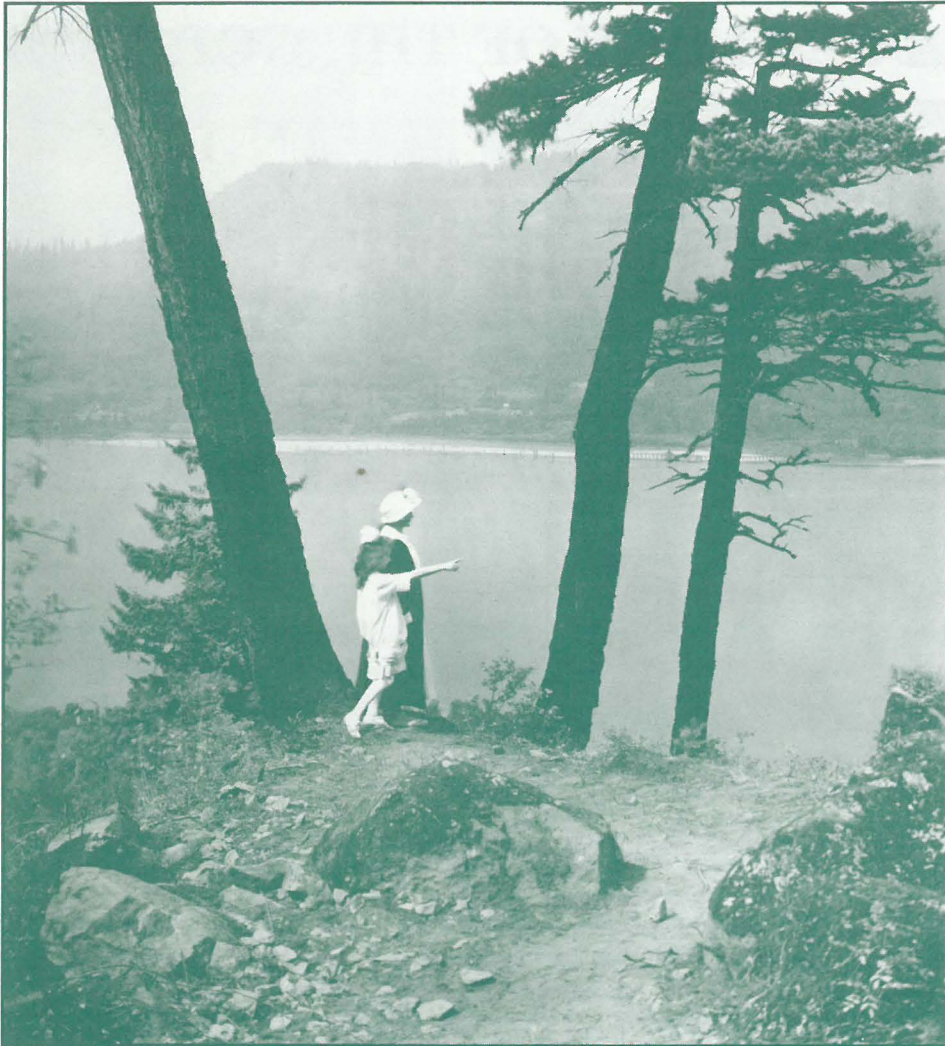

## SUMMER PICNIC

*Come join us for the 1989 Summer Picnic:*

Date: Sunday, July 16  
Time: 12:00 noon to 7:00 p.m.  
Place: The Shire

The Shire is a private nature preserve on the Washington shore of the Columbia River, just across from Multnomah Falls. The green lawn is perfect for picnicking, and it slopes down to a beautiful bay, just right for a swim. Bring your friends, kids, bathing suits, suntan lotion, kites, beach balls, binoculars for birdwatching, and a big picnic basket.

Members who have not yet been to The Shire are in for a treat. It is not open to the public, and the annual Friends picnic is a rare opportunity to visit a serene and special place.

The Shire is about 29 miles east of Vancouver. Turn off on the south side of

Washington Highway 14, just across from the Skamania County Shops between mileposts 28 and 29. Look for the gravel piles and chainlink fence on the north side of the road and turn off the highway to the south through a red gate (which is quite inconspicuous until you get close).

If you are coming from the east, be very careful in making your turn across the highway. If you are coming from the west, there is a gravel shoulder where you can pull off to make your turn. After you come through the gate, proceed with caution as you cross the tracks of the Burlington Northern railroad, and then drive down to the parking area.

On Saturday, June 24 and Sunday, June 25, hikers will converge on the Columbia River Gorge for the Ninth Annual Gorge Hiking Weekend. This year 34 hikes, a bicycle trip and, for the first time, an overnight horseback trip (for riders with their own horses) will be offered. Some of this year's hikes include:

**Catherine Creek (Saturday):** An easy hike in a wonderful wildflower area, which has come into public ownership since the National Scenic Area Act was passed. (For more information on Catherine Creek, see page 3.)

**Multnomah-Wahkeena Falls Photo Hike (Sunday):** A special hike for photographers, designed to capture splendid views of Multnomah and Wahkeena Falls and the Columbia River.

**Nesmith Point (Sunday):** Peter Bond of Oregon State Parks will lead this strenuous hike, a steep climb up to a former fire lookout site with a breathtaking view of the Gorge.

The complete Hiking Weekend brochure will be sent to members in early May. In the meantime, mark your calendars so you won't miss out on the big event.

The traditional After-Hike Rendezvous will take place each day from 11:00 a.m. to 5:00 p.m. On Saturday, Byron Gardner will speak on the art of falconry and the program to reintroduce peregrine falcons in the Gorge -- and he will bring along his own hunting falcon. On Sunday, we will have Marvin Beeson speaking on the dramatic geology of the Gorge.



# MAPPING THE GEOLOGY OF THE GORGE



*John Eliot Allen took this photo in 1931 of his fellow graduate students relaxing at "Sunny Site."*

## AND MOUNT HOOD IN 1931

by John Eliot Allen  
Professor Emeritus  
Portland State University

Directly after my graduation from the University of Oregon in 1931, I spent 13 weeks, from June 6th to September 15th, helping map the geology for tens of miles on both sides of the Columbia between Troutdale and Hood River. The only day off was the Fourth of July.

### The Field Party

The field party consisted of Dr. Edwin T. Hodge of the University of Oregon, and 10 students: myself, Richard Bogue, Meredith Sheets, Allan Griggs, Howard Handley, Wilbur Greenup and four others whose names I do not recall.

Three of us were to use this mapping in the preparation of Master's Theses obtained the following year. My thesis was on the northern half of the nearly 1500 square miles we mapped (which included the Gorge), Sheet's covered the southern half (which went as far south as Estacada), and Bogue's was on the description of the different types of rocks in the area.

### On the Seventh Day We Cooked

The schedule was staggered so that each of us worked six days in the field, and on the seventh day cooked breakfast and dinner for the entire crew and did personal washing and camp tending. Several of us had never cooked for a large group before, and I well remember the time Sheets cooked a pound of rice, which eventually almost filled a wash tub! He later did the same thing with dried apples.

Since Dr. Hodge had only \$2,000 to finance the entire summer, we had almost no meat except lunch meat for sandwiches. Rice, oatmeal, macaroni and cheese, and prunes were staples.

Dr. Hodge would drop us off alone on a road at 8:00 a.m., and we had to finish our 8 to 10 mile traverse (usually with only the skimpiest of trails) and be ready to be picked up at an assigned place at 5:00 p.m. sharp. The car did not wait. If we missed it, we either walked back to camp (5 to 20 miles) or camped out all night. During the summer, only Allan Griggs and myself did not join the OAN (Out All Night) Club!

Our tent camp for four weeks in the Gorge was called "Sunny Site," since it was one that was not in the shadow of the cliffs. Each of us would be dropped off along the Scenic Highway, which was already by 1931 beginning to be crowded. Many times a trip to Portland took two hours of bumper-to-bumper driving, following big trucks grinding their way slowly up the switchbacks east of Crown Point and Rowena Dell.

### Scouting the Territory

I mapped on the north side of the Gorge for one week, coming in most evenings black from head to foot with charcoal picked up by crawling over logs burned in the great Yacolt fire of 1929. It and the previous one of 1910 burned nearly 400 square miles in Washington.

Within nearly every mile along the south side of the Gorge I climbed a ridge or canyon, and well remember seeing, from a vantage on the ridge above St. Peter's Dome, one of the first autogyros to visit Oregon whirling down the canyon below me.

### The Professor's Revenge

Another time, Hodge wanted me to take him to the top of Yeon Mountain, so that he could scout out the geology. He was a master at doing the geology by eye for miles around.



By this time I was in the best shape I have ever been in (I hiked from the highway into Wahtum Lake and back in one afternoon!) so I took the lead, and gradually stepped up the pace till we got to the top. Hodge tried to keep up with me, and was so tired that he couldn't eat his lunch, which I did for him!

The scariest experience I had in the Gorge was with Dr. Hodge, a notoriously poor driver, coming the 2,000 feet down Bridal Veil Creek on the Palmer Mill Road, when the brakes on our ancient Dodge touring car gave out. He managed to keep on the narrow road by driving into the bank and scraping along for a hundred feet before stopping. We went the rest of the way down in low gear.

## Death-Defying Feats Among the Glaciers

After we had completed mapping the Gorge, we moved to Government Camp to map Mount Hood. One morning Hodge drove Bogue and me to timberline (now the site of Timberline Lodge) on Mount Hood and left us there at 6:00 a.m.

I was supposed to map Crater Rock, cross over the col above Illumination Rock onto Reid Glacier, and then traverse Yokum Ridge north of the glacier from as far as I could get up onto the ridge, down to the end of the road on the Sandy River. (Originally Hodge had wanted me to climb to the summit and go all the way down Yokum Ridge, but I had had enough mountaineering experience to balk). Bogue accompanied me to the col and then went down the ridge south of Reid Glacier. We parted at 9:00 a.m., my only equipment being a pair of crampons and my G-pick (no ice axe!).

I jumped across a 6-foot bergschrund crevasse to get onto the glacier, and crossed to the north wall. It turned out to be



*John Eliot Allen at the beginning of a day.*

made up almost entirely of mudflow materials, so loosely consolidated that the boulders would pull out if you put any weight on them. I worked my way down the glacier, hoping to find a climbing route, and discovered that Reid Glacier cascaded over a 200-foot ice-fall of serac ice, so I could go no further. I finally found a chimney, and got to the top of Yokum Ridge at noon.

By that time I was so scared that I didn't take time out for lunch. In trying to go down the ridge, I ran into a series of vertical cliffs. My next attempt was to try to descend the north side of the ridge onto Sandy Glacier, and after what now seems like hours of exploring dead-end ledges and chimneys finally managed to get back onto glacier ice. It was after two o'clock, and I stopped to eat lunch and write up what I remembered of the geology. I by-passed the cliffs by going down Sandy Glacier, and came out on top of the ridge again at three o'clock.

It was still 10 miles to the point where the car was to pick me up at 5:00 p.m., and the summer windstorm of 1930 had blown down all the trees along the ridge, so I had to side-hill for several miles before I finally got to the meeting place at 7:30 p.m. Allan Griggs saved me from a night out by coming back on a second trip. Bogue got caught in a talus slide, injured his hand and couldn't even make it to the road that night, but was picked up the next morning.

## A Memorable Meal

In mapping the north side of Mount Hood, Bogue and I were dropped off at Cloud Cap for a three-day traverse. The procedure was to have one of us go up and one go down each of three ridges. By the end of the second day, we had run out of provisions, and had only a handful of rice and a few raisins left.

It was my turn to go down the ridge, and I spied a lumber camp in the valley below. I approached the boss and told him of our plight, and he sent me to the bull-cook with orders that I could have anything I wanted. Since we had had almost no meat all summer, I chose a large round steak, and he cut one off that was nearly a foot across. When he said, "Would that do?" I replied, "Well, there are two of us," and he cut off a second steak.

I could only carry what would go into a small World War I gas mask bag, so I picked out a can of smoked oysters and a can of fruit to complete the meal. I got back to our spike-camp at about six o'clock, built a fire, and while it was burning down to a good bed of coals, fashioned a willow-wand grill. It was beginning to get dark and I was starved, so I put my steak on the fire and enjoyed my first gourmet meal in many weeks.

Just as I was finishing, I heard Dick Bogue stumbling down the trail in the dark, and put his steak on the grill. When he got near enough to hear me, I called, "Hey, Dick, how would you like a nice big juicy round steak for supper?" His reply was completely unprintable! When he arrived, he couldn't believe his eyes, and we sat there laughing like idiots.

I never forgave Hodge for sending us alone on such hazardous trips, and as a result I have made it a firm policy never to send geologists out alone in rough country.

I finished my M.A. thesis on the geology of the Gorge the next year, teaching laboratories part time for \$250 for the year. My love affair with the wonders of the Columbia River Gorge has never flagged.

*This tale is extracted from Chapter 6 of Professor Allen's autobiography, "Bin Rock and Dump Rock."*

# GUIDED TOUR TAPES NOW AVAILABLE

The new Columbia River Gorge Guided Tour tapes are now available at the Friends of the Columbia Gorge office and at other selected locations, including Powell's Bookstores, Norm Thompson, Made in Oregon, Pacific Arts, Budget Tapes, Django's, the Oregon Historical Society and the Portland Audubon Society in Portland, and at Tymer's Camera Store in Vancouver.

The tour is designed for people to use in their car cassette players as they travel through the Gorge. One cassette covers the Oregon side of the Gorge, from Portland to The Dalles, and the other covers the Washington side, from Maryhill back to Vancouver.

Efficient travelers can complete the tour in one day, but we recommend allowing two full days. If you bring your hiking boots and test out a trail or two, or your swimsuit for one of the Gorge's "old swimmin' holes," you will need the extra time.

The Tour tells about the fascinating geology of the Gorge, legends of its Indian tribes, and hair-raising tales of the Old Oregon Trail. It also lets you know where to look for some of the Gorge's prettiest wildflowers and most breathtaking views.

Jack McGowan, of television's "P.M. Magazine," and Deb Williams, a former radio announcer, narrate the tour, which also includes background music by Michael Kearsay. David Kelley wrote the script, and Dennis Wiancko directed the production of the Tour.

The Tour sells for \$19.95. Members of Friends of the Columbia Gorge receive a 15% discount if they buy directly from the organization.

# MEMORIAL CONTRIBUTIONS

**In memory of  
Frank Batey**

by  
Elva Olson Michael

**In memory of  
Borden Beck**

by  
Carolyn Schink

**In memory of  
Dr. Edward W. Davis**

by  
Mrs. J. W. Emahiser

**In memory of  
Robert Neighbor**

by  
Sophia S. Bingham  
Mr. and Mrs. H. B. Cooper  
Robert and Helen Gamble  
Joan Gamble Hering  
John B. Marks  
Nancie S. McGraw  
Bruce Russell

**In memory of  
Joan M. Polson**

by  
Fellow employees of  
Clackamas County Building Services Division  
Members of the  
Oregon Speech and Hearing Association  
Chris and Lorene Lamp  
D. F. and Carol Middleton  
Diane Fox

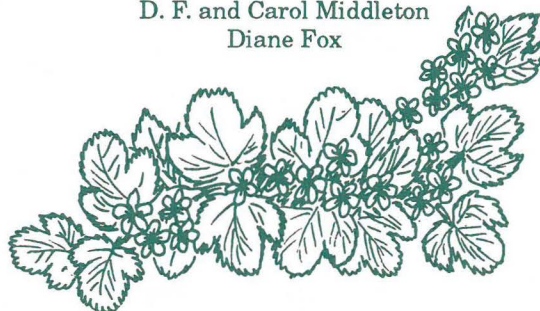

## IN REMEMBRANCE

On April 9, 1988, Glenn Replogle, an energetic young man who greatly enjoyed the grandeur of the Columbia River Gorge, died in a tragic fall from a cliff east of Horsetail Falls. His parents, Mr. and Mrs. David Replogle, designated Friends of the Columbia Gorge to receive memorial contributions, and many individuals made generous donations in Glenn's memory.

Recently, the Forest Service and Friends of the Columbia Gorge have arranged to place a memorial plaque in the Horsetail Falls area to honor Glenn Replogle's memory. We hope that this plaque will also remind hikers of the precautions that are necessary when hiking in cliffside areas.

Please send me \_\_\_ copies of the

### **COLUMBIA RIVER GORGE GUIDED TOUR**

\_\_\_ at the member's discount price of \$16.95  
\_\_\_ at the regular price of \$19.95

plus \$2.00 shipping and handling for the first Tour  
and \$1.00 for each additional Tour

Name: \_\_\_\_\_

Address: \_\_\_\_\_

City/State: \_\_\_\_\_ Zip: \_\_\_\_\_

Daytime Telephone: \_\_\_\_\_

Total Enclosed: \$ \_\_\_\_\_



*This John Fery painting, "Palisades of the Columbia" is one of the landscapes featured in the Maryhill Museum's current show. Photograph courtesy of Maryhill Museum of Art.*

## MARYHILL MUSEUM FEATURES GORGE LANDSCAPES

**H**istoric and contemporary landscapes of the Columbia River Gorge are being featured in the show, *Roll On, Columbia*, now through June 25 at the Maryhill Museum. Several special events have been scheduled in connection with the show:

**Saturday, April 15, 2:00 p.m.** -- Terry Toedemeier will present a slide-illustrated lecture on the history of photography in the Gorge.

**Tuesday, May 9, 11:00 a.m.** -- Gladys Seufert will show historic slides of the Gorge and discuss how the profile of its landscape has been changed by the introduction of dam development.

**Saturday, May 20, 3:00 p.m.** -- Charles Deemer will present his one-person recreation of Woody Guthrie and his era, using excerpts from Guthrie's journals and songs.

The Museum's regular admission charge is \$3.00. Special rates are available for seniors and young people. There is no additional admission charge for the special events. For more information, call the Maryhill Museum at (509) 773-3733.

## VOLUNTEERS NEEDED FOR VEGETATION SCREENING PROJECT

**F**riends of the Columbia Gorge is sponsoring an attempt to complete a vegetation barrier between I-84 eastbound and the trailer court at the east end of Cascade Locks. Some years ago, a chain link fence and some ivy was installed there. Unfortunately, although the ivy now forms a dense ground cover along the fence, it has not successfully climbed the fence to screen the trailer court.

This project will work on training the existing ivy up the fence and encouraging it to grow. Since ivy is not native to the Gorge, it is not normally a desirable vegetation. In this case, however, it is already present, and is in an isolated location where it cannot spread to areas of native vegetation. We will also test-plant some native species to determine their usefulness.

If you are interested in helping with this project, please call Barbara Robinson, weekday evenings, at (503) 631-2054.

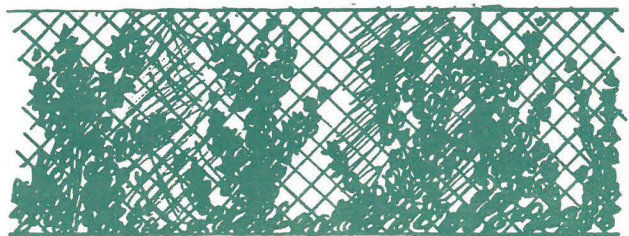

## MISSION STATEMENT

**F**riends of the Columbia Gorge shall vigorously protect the scenic, natural, cultural, historic and recreational values of the Columbia River Gorge, encourage compatible economic development within the urban areas, and educate people about the Gorge in order to gain the public support necessary for effective implementation of the National Scenic Area Act.

### Staff

Margaret Donsbach, Executive Director  
Gary Kahn, Land Use Counsel  
Cheryl Dye, Office Manager

### Board of Directors

Michael Adler  
Bill Bell  
B. H. Bishop  
Bowen Blair, Jr.  
Phyllis Clausen  
Debbie Craig  
Tim Hibbitts  
Jeff Hunter  
Sharron Lankton  
Elmer Lierman  
Kate McCarthy  
Nancie McGraw  
Douglas Medler  
Kate Mills  
Nancy Moller  
Yvonne Montchalin  
Jeanne Norton  
Doug and Judy Reid  
Tom Reynolds  
Ed Robertson  
Nancy Russell  
Michael Ryan  
Lynda Sacamano  
Larry Upson  
Christina Wilson  
Henry Wessinger

### Contributing Writers

John Eliot Allen  
Margaret Donsbach  
Russ Jolley  
Barbara Robinson  
Nancy Russell

### Photography Credits

John Eliot Allen  
Blair Csuti  
Marie Hall  
Russ Jolley

*printed on recycled paper*

## Friends of the Columbia Gorge

319 S.W. Washington, #420  
Portland, Oregon 97204

Non-Profit Org.  
Bulk Rate  
U.S. Postage  
**PAID**  
PORTLAND, OR  
PERMIT NO. 2623

*Postmaster: Address correction requested*

## NANCY RUSSELL'S WILDFLOWERS: Lewisia Rediviva

**O**n a day in early May in the 1970's I stopped a few miles east of Hood River to explore for new plants. Over the railroad tracks, through the poison oak, up a steep embankment, and out onto a rocky ledge overlooking the Columbia I went. There at my feet, growing right out of the rock was a plant that was all flower and no greenery -- just delicate bouquets of pink and white lying flat on the ground. This was the first lewisia of my experience -- the famous *Lewisia rediviva*. The genus is named for Meriwether Lewis, who found it on his return east from Oregon territory on July 1, 1806. Lewis put it between layers of paper in a botanical press and took it to Philadelphia where, many months later, the dried specimen startled botanist Frederick Pursh by proceeding to grow! Its unexpected revival inspired Pursh to call it "rediviva."

## IS YOUR MEMBERSHIP CURRENT?

**S**ome recent members who came to the March 19 special membership meeting were astonished to find that their memberships had expired. The situation is partly our fault. Due to recent administrative pressures, we have not yet sent out membership renewal notices for memberships which expired in February, March or April. We also have not sent second notices yet for memberships which expired in December and January.

This issue of the newsletter is being sent to all members who were current as of December, 1988. But if your membership expires before June 1, 1989, you will not receive the June newsletter unless you renew before June.

The date your membership expires is printed on your mailing label alongside your membership number and just above your name. Please renew. Don't miss out on your newsletter and other membership privileges!